

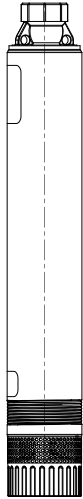

**Franklin Electric**

# C1-SERIES CISTERN OWNER'S MANUAL



## **BEFORE YOU START**

**BEFORE INSTALLING PUMP, BE SURE TO READ THIS OWNER'S MANUAL CAREFULLY.**

**REFER TO PRODUCT DATA PLATE(S) FOR ADDITIONAL OPERATING INSTRUCTIONS AND SPECIFICATIONS.**

### **CAUTION**

- Keep work area clean, well-lit and uncluttered.
- Keep safety labels clean and in good condition.
- Wear safety glasses while installing or performing maintenance on pump.
- Adhere to the guidelines of the National Electric Code (NEC) or Canadian Electric Code (CEC), and any other state and local codes for ALL electrical installations. Check with the appropriate agencies or contact a licensed electrician.
- Most water system problems result from improper installation. It is suggested that you read this manual carefully before installing your pump.
- Check and make available all the tools you will need to install your pump. Required tooling may include wrenches, pipe sealant, pipe fittings and nipples, screwdriver, etc. Be sure to have available proper and adequate wiring material to complete the installation correctly.

## **READ AND FOLLOW SAFETY INSTRUCTIONS**



This is the safety alert symbol. When you see this symbol on your pump or in the manual, look for one of the following signal words and be alert to the potential for personal injury:

### **DANGER**

warns about hazards that will cause serious personal injury, death or major property damage if ignored.

### **WARNING**

warns about hazards that can cause serious personal injury, death or major property damage if ignored.

### **CAUTION**

warns about hazards that will or can cause minor personal injury or major property damage if ignored.

The label **NOTICE** indicates special instructions, which are important but not related to hazards.

**Carefully read and follow all safety instructions in this manual and on pump.**

**Keep safety labels in good condition.**

**Replace missing or damaged safety labels.**



### **WARNING**

**HAZARDOUS PRESSURE.** Do not run pump against closed discharge. Release all system pressure before working on any component. Under certain conditions, submersible pumps can develop extremely high pressure. Install a pressure relief valve, which is capable of draining the pumps max output at the relief valves rated pressure.

**Do not run pump dry.** Pump must be fully submersed in water prior to starting. If run without water, the pump and motor will be damaged.

## **Electrical Safety**

### **CAUTION**

Make sure all **ELECTRICAL POWER IS OFF** before connecting any electrical wires.



**⚠ WARNING**



**Hazardous voltage. Can shock, burn, or cause death.**

Ground pump before connecting to power supply. Disconnect power before working on pump, motor or tank

- ⚠ Wire motor for correct voltage. See "Electrical Installation" section of this manual and motor nameplate. The C1-Series is available to operate on either 230V or 115V input power. Check product nameplate to determine correct input voltage.
- ⚠ Ground motor before connecting to power supply. Pump is supplied with a copper ground wire. Use only copper wire for pump connection.
- ⚠ DO NOT GROUND PUMP TO A GAS SUPPLY LINE.
- ⚠ Meet National Electrical Code (NEC) or Canadian Electrical Code (CEC) and local codes for all wiring.
- ⚠ Follow all pump wiring instructions provided in this manual.

## **C1-Series KEY FEATURES**

### **Pump Features:**

- Available in 10, 20, and 30 gallons per minute (gpm).
- All pumps are powered by a high quality 0.5 hp submersible motor.
- 1.25-inch NPT pump outlet.
- Bottom suction design to allow for the unit to pump longer and more reliably without losing its prime.
- Available in both 115V and 230V options.
- Motor protected thermally by a built in overload.
- Built for long life in gray water and effluent pumping applications.
- Stainless steel and precision molded industry standard thermal plastic construction for all wetted surfaces.
- 10' SJOOW power cord designed specifically for effluent pumping.
- Supplied with a removable 5" base for secure and reliable mounting.

### **⚠ ATTENTION**

IMPORTANT INFORMATION FOR INSTALLERS OF THIS EQUIPMENT! THIS EQUIPMENT IS INTENDED FOR INSTALLATION BY TECHNICALLY QUALIFIED PERSONNEL. FAILURE TO INSTALL IT IN COMPLIANCE WITH NATIONAL AND LOCAL ELECTRICAL CODES, AND WITHIN FRANKLIN ELECTRIC RECOMMENDATIONS, MAY RESULT IN ELECTRICAL SHOCK OR FIRE HAZARD, UNSATISFACTORY PERFORMANCE, AND EQUIPMENT FAILURE. FRANKLIN INSTALLATION INFORMATION IS AVAILABLE FROM PUMP MANUFACTURERS AND DISTRIBUTORS, AND DIRECTLY FROM FRANKLIN ELECTRIC. **CALL FRANKLIN TOLL FREE 800-348-2420 FOR INFORMATION.**

### **⚠ WARNING**

SERIOUS OR FATAL ELECTRICAL SHOCK MAY RESULT FROM FAILURE TO CONNECT THE INLINE SYSTEM, METAL PLUMBING, AND ALL OTHER METAL NEAR THE C1-SERIES SYSTEM OR CABLE, TO THE POWER SUPPLY GROUND TERMINAL USING WIRE NO SMALLER THAN MOTOR CABLE WIRES. TO REDUCE RISK OF ELECTRICAL SHOCK, DISCONNECT POWER BEFORE WORKING ON OR AROUND THE WATER SYSTEM. DO NOT USE C1-SERIES SYSTEM IN SWIMMING AREAS.

### **General Safety**

The Franklin Electric C1-Series cistern pumping system is designed and approved for use in effluent pumping applications. Do not allow pump or any system plumbing to freeze. To do so will void the warranty.

This pump has been evaluated for pumping water only. Pumping liquids other than water may void warranty. Periodically inspect pump and system components.

## **INSPECT YOUR SHIPMENT**

All Franklin Electric C1-Series are carefully tested, inspected, and packaged to insure their arrival in perfect condition. When the pump is received, examine it closely to make sure there is no damage that may have occurred in shipping. If damage is evident, report this immediately to your shipping carrier and product dealer. The shipping carrier assumes full responsibility for the shipment's safe arrival. Any claim for damage to the shipment, either visible or concealed, must be made through the shipping carrier first.

## **INSTALLATION**

### **Location Of The C1-Series Pump**

The C1-Series is designed to be installed in a cistern gray water/effluent environment. The pump should be protected to prevent possible freezing.

If a sewage tank is near or a part of the system where the C1-Series pump is installed, proper ventilation is required to meet all local and national codes.

### **NOTICE: READ AND FOLLOW ALL INSTRUCTIONS!**

- ⚠ Disconnect power at electrical panel before making any electrical connections.
- ⚠ Adhere to the guidelines of national, state and local plumbing codes when installing this product. Check with the appropriate agencies or water systems professional for additional information.
- ⚠ Supply voltage must be +/- 10% of motor nameplate voltage. Low or high voltage can damage the motor and will void the warranty.
- ⚠ If possible, connect pump to dedicated branch circuit with no other appliances on it.
- ⚠ Do not operate pump unless pump is grounded.
- ⚠ Solder and tape all spliced connections carefully. A fused disconnect switch or circuit breaker should be placed at or near the pump.

## ELECTRICAL INSTALLATION

1. Employ a licensed electrician to perform the wiring. All wiring must be done in accordance with applicable national and local electrical codes.
2. Disconnect electrical power at the main breaker.
3. Check that the power supply corresponds with the electrical rating of the submersible motor.
4. Every installation requires a fused disconnect switch or circuit breaker.
5. Every installation must be grounded. There must be a reliable ground connection between the pump and the distribution panel. The motor lead incorporates a green grounding conductor.
6. A 2-wire C1-Series has two power supply wires and one ground wire, and does not require a motor control box, since all electrical components are built inside the motor. FIGURE 1 shows a typical wiring diagram for a 2-wire installation.
7. Use an ohmmeter to make continuity and insulation checks after the installation is completed.

**FIGURE 1 - 2-WIRE, 1 Phase, 1/2 thru 1-1/2 HP Pump Wiring Diagram**

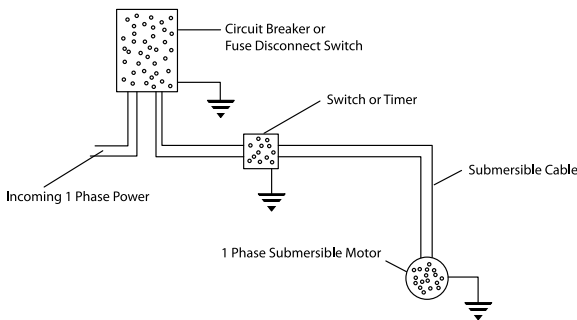

## Plumbing, Piping, And Hoses

In general, keep the discharge line as large as possible. Avoid using bends, elbows and fittings whenever possible. All discharge connections must be airtight, the use of pipe compound/or Teflon tape is recommended for all threaded joints.

## Flow Capacity By Pipe Size

The discharge pipe diameter should be selected not to exceed a maximum water velocity of 8 ft/sec. Use the table below (FIGURE 2) for selection of the proper pipe sizes based on the overall system's output.

**FIGURE 2 - Flow Capacity By Pipe Size**

Minimum Pipe Diameter	Maximum Flow Rate GPM
1/2"	4.9
3/4"	11.0
1"	19.6
1-1/4"	30.6
1-1/2"	44.1

## Water Supply Requirement

The C1-Series is designed to pump water from a cistern holding tank. The unit should be kept completely full of water at all times. The system should not be run dry, without water, for even short periods of time, as this will cause damage to the pump and the pumping system.

## Horizontal Offset Suction Piping

When the pump is offset a long distance from the end point of fluid discharge, the horizontal offset suction piping may have to be increased in diameter to reduce friction loss. The friction loss in a system increases:

1. As the flow rate increases.
2. As the piping size decreases.

Refer to the included C1-Series performance curves (Appendix 1) and friction loss tables (Appendix 2) to determine the amount of head lost for a given application.

## PUMP INSTALLATION PROCEDURE

1. Disconnect electrical power at the main breaker.
2. A qualified professional installer should be used to install the pump system and any associated control devices.
3. Pump is not to be installed in a hazardous environment. Hazardous locations are defined by the National Electrical Code, ANSI/NFPA 70-1984.
4. C1-Series pumps are designed for permanent installations only. All power connections should use approved connection box strain reliefs to ensure that undue stress is not put upon the units power cord. All system control boxes and or electrical panels must be UL/CSA listed and approved as suitable for the particular end use application of the product.
5. The products electrical lead/cord is not intended to be used to transport or install the unit. If the unit must be lowered into its place of operation, do so by way of threading a fixed pipe into the pumps discharge. DO NOT lower the unit by the factory installed electrical cord.
6. The pump discharge is 1.25-inch.

**NOTICE:** This pump is designed for a maximum submergence of 85 feet (25 meters). Installation beyond this depth can cause damage to the pump and plumbing system.

7. To facilitate priming and starting of the pump, it is recommended that a valve be placed in the discharge plumbing. This valve is critical if the unit will be operated on a regular basis at near maximum discharge. To use the valve to assist in the pumps priming and start up, first close the valve completely. Fill the pump and plumbing completely with water. Next, crack the valve open to allow any air in the system to bleed off once the system is turned on. Start the pump. As water begins to flow, slowly open the valve the rest of the way until the desired flow rate is achieved.

## OPERATION

### Priming

Never run the pump dry. To prime, fully submerge the pump and its discharge connection under water prior to starting the pump's motor.

### WARNING

**HAZARDOUS PRESSURE:** Do not run pumps against a closed discharge, or at a system operating pressure above what is mentioned by the pump manufacturer.

## Starting

Close all system outlets, then slightly crack one system outlet to allow excess air to bleed out of the system. Start the pump. Immediately upon starting, slowly begin opening the discharge valve until half open. If after a few minutes of running you do not get water, repeat priming process (the pump may be locked by excess air that is trapped in the unit). Once the pump is operating, fully open the discharge valve and a system outlet, letting the pump operate until the water is running clear. No further priming should be needed unless the pump is drained or there is a leak in the suction plumbing.

## Process To Ensure Pump Is Receiving Enough Water To Meet Demand

1. Install a shut-off valve in the plumbing near the discharge of the pump.
2. Close the valve, but make sure that the supply water is allowed to freely flow into the pump without restriction.
3. Turn on the pump, and begin opening the discharge's shut-off valve.
4. Continue opening the discharge valve until a very distinct noise is heard coming from the pump. This noise is called Cavitation (which can destroy the pump over time), and will sound like there is gravel inside the pump. STOP opening the discharge valve once cavitation is heard.
5. Slowly close the discharge valve until the cavitation is no longer heard.
6. The pump is now adjusted so that the system demand will not exceed what can be supplied.

To ensure that the system is never run dry, it may be necessary to set up a float switch system. The float switch should be adjusted to allow the pump to remove the most water possible, but not so much that the water level goes below the pumps suction screen. If the water goes below the suction screen, air will be drawn into the pump. Pumping air for an extended period of time could damage or destroy the pumping system

## Lubrication

The pump requires only water for lubrication and must never be run dry.

### WARNING

Before disconnecting pump, be sure fuse box leads are disconnected or power is turned off. After reassembling the pump, refer to priming instructions before running.

## INSTALLATION RECORDS

To keep an accurate record of your installation, be sure to fill out the data below:

Date of Installation: \_\_\_\_\_

Model Number: \_\_\_\_\_

Serial Number: \_\_\_\_\_

Tank/Cistern Size (volume/height/diameter): \_\_\_\_\_

### Tank/Cistern Location

Above Ground: \_\_\_\_\_ Below Ground: \_\_\_\_\_

### Cistern Source

Municipal Supply: \_\_\_\_\_ \*Well Supply: \_\_\_\_\_ \*Other Supply: \_\_\_\_\_

*If the source is a well note the well data:*

#### \*Well Data (Only use if well supplied cistern)

Depth of Well (ft.): \_\_\_\_\_

Depth to Water (ft.): \_\_\_\_\_

Inside Diameter of Well: \_\_\_\_\_

*If the cistern is supplied with water from a pressurized source note the following:*

#### \*Other Supply Source

Incoming Pressure (psi): \_\_\_\_\_

Diameter of Supply Line (in): \_\_\_\_\_

Incoming Flow Available (gpm): \_\_\_\_\_

### Installation Parameters

Discharge Pipe :

Material: \_\_\_\_\_

Diameter: \_\_\_\_\_ Length: \_\_\_\_\_

Lead Wire:

Gauge: \_\_\_\_\_ Length: \_\_\_\_\_ Jacket: \_\_\_\_\_

Incoming Voltage: \_\_\_\_\_

Operating Pressure: \_\_\_\_\_

Operating Flow: \_\_\_\_\_

**APPENDIX 1 - C1 PERFORMANCE CURVES**

**C1 Series Family Curve**

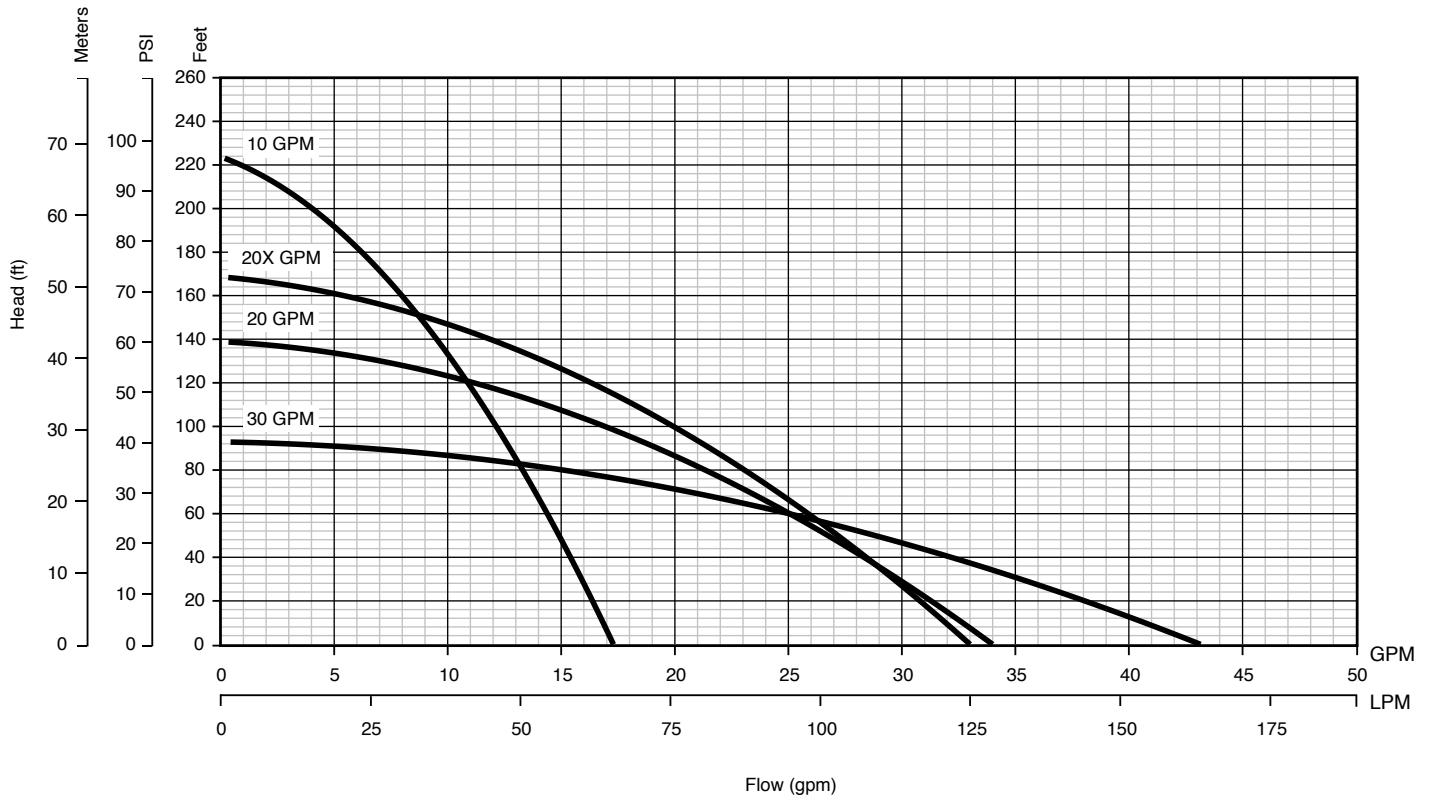

## APPENDIX 2 - FRICTION LOSS TABLES

Note: Chart shows friction loss per 100' of pipe.

To convert to friction loss per foot, move decimal point two places to the left.

1"

Schedule 40 pipe 1.049 in. i.d. / Type L Copper tube 1.025 in. i.d.					
GPM	Velocity Ft/S	Friction Loss		Velocity Ft/S	Ft Hd./ 100' Pipe Fric. Loss C=130
		Ft Hd./100' of pipe			
		Steel C=100	PVC C=140		
2.0	0.74	0.60	0.32	.078	0.41
3.0	1.11	1.26	0.68	1.17	0.87
4.0	1.49	2.14	1.15	1.56	1.48
5.0	1.86	3.24	1.75	1.95	2.23
6.0	2.23	4.54	2.45	2.34	3.13
8.0	2.97	7.73	4.16	3.11	5.35
10	3.71	11.7	6.31	3.89	8.08
12	4.46	16.4	8.85	4.67	11.3
14	5.20	21.8	11.8	5.45	15.0
16	5.94	27.9	15.1	6.22	19.2
18	6.68	34.7	18.7	7.00	23.9
20	7.43	42.1	22.8	7.78	29.0
25	9.29	63.6	34.6	9.74	43.9
30	11.1	89.2	48.1	11.7	61.4
40	14.9	152	82.0	15.5	105

1-1/4"

Schedule 40 pipe 1.380 in. i.d. / Type L Copper tube 1.265 in. i.d.					
GPM	Velocity Ft/S	Friction Loss		Velocity Ft/S	Ft Hd./ 100' Pipe Fric. Loss C=130
		Ft Hd./100' of pipe			
		Steel C=100	PVC C=140		
4.0	0.86	0.56	0.30	1.02	0.52
6.0	1.29	1.20	0.65	1.53	1.12
8.0	1.72	2.04	1.10	2.04	1.92
10	2.15	3.08	1.67	2.55	2.90
12	2.57	4.31	2.33	3.06	4.04
14	2.99	5.73	3.10	3.57	5.35
16	3.43	7.34	3.96	4.08	6.85
18	3.86	9.13	4.93	4.59	8.52
20	4.29	11.1	6.00	5.10	10.4
25	5.36	16.8	9.06	6.38	15.7
30	6.43	23.5	12.7	7.65	22.1
40	8.58	40.0	21.6	10.2	37.6
50	10.7	60.4	32.6	12.8	56.7
60	12.9	84.7	45.6	15.3	79.5
80	17.2	144	77.9	20.4	136

1-1/2"

Schedule 40 pipe 1.610 in. i.d. / Type L Copper tube 1.505 in. i.d.					
GPM	Velocity Ft/S	Friction Loss		Velocity Ft/S	Ft Hd./ 100' Pipe Fric. Loss C=130
		Ft Hd./100' of pipe			
		Steel C=100	PVC C=140		
6.0	0.95	0.57	0.31	1.08	0.49
8.0	1.26	0.96	0.52	1.44	0.82
10	1.58	1.45	0.79	1.80	1.24
12	1.89	2.04	1.10	2.16	1.73
15	2.36	2.95	1.59	2.70	2.62
20	3.15	5.24	2.83	3.60	4.46
25	3.94	7.90	4.26	4.51	6.74
30	4.73	11.1	6.00	5.41	9.44
40	6.30	18.9	10.2	7.21	16.1
50	7.88	28.5	15.4	9.01	24.3
60	9.46	40.0	21.6	10.8	34.1
70	11.0	53.2	28.7	12.6	45.5
80	12.6	68.1	36.8	14.4	58.1
90	14.2	84.7	45.7	16.2	72.1
100	15.8	103	56.6	18.0	87.7

2"

Schedule 40 pipe 2.067 in. i.d. / Type L Copper tube 1.985 in. i.d.					
GPM	Velocity Ft/S	Friction Loss		Velocity Ft/S	Ft Hd./ 100' Pipe Fric. Loss C=130
		Ft Hd./100' of pipe			
		Steel C=100	PVC C=140		
10	0.96	0.43	0.23	1.07	0.35
15	1.44	0.92	0.50	1.60	.075
20	1.91	1.55	0.84	2.13	1.24
25	2.39	2.35	1.27	2.66	1.87
30	2.87	3.29	1.78	3.19	2.62
40	3.82	5.60	3.03	4.26	4.48
50	4.78	8.46	4.57	5.32	6.76
60	5.74	11.9	6.44	6.39	9.47
70	6.69	15.8	8.53	7.45	12.6
80	7.65	20.2	10.9	8.52	16.2
90	8.61	25.1	13.6	9.58	20.0
100	9.56	30.5	16.5	10.7	24.4
120	11.5	42.7	23.1	12.8	34.1
150	14.3	64.7	35.0	16.0	51.6
200	19.1	110	59.4	21.3	87.8

## LIMITED WARRANTY\*

THIS WARRANTY SETS FORTH THE COMPANY'S SOLE OBLIGATION AND PURCHASER'S EXCLUSIVE REMEDY FOR DEFECTIVE PRODUCT.

Franklin Electric Company, Inc. and its subsidiaries (hereafter "the Company") warrants that the products accompanied by this warranty are free from defects in material or workmanship of the Company.

The Company has the right to inspect any product returned under warranty to confirm that the product contains a defect in material or workmanship. The Company shall have the sole right to choose whether to repair or replace defective equipment, parts, or components.

The buyer should return the product to the place of purchase for warranty consideration. Subject to the terms and conditions listed below, the Company will repair or replace to the buyer any portion of this product which proves defective due to materials or workmanship of the Company.

The Company will consider products for warranty for 12 months from the date of installation or for 24 months from the date of manufacture, whichever occurs first.

The Company shall IN NO EVENT be responsible or liable for the cost of field labor or other charges incurred by any customer in removing and/or affixing any product, part or component thereof.

The Company reserves the right to change or improve its products or any portions thereof without being obligated to provide such change or improvement to previously sold products.

THIS WARRANTY DOES NOT APPLY TO products damaged by acts of God, including lightning, normal wear and tear, normal maintenance services and the parts used in connection with such service, or any other conditions beyond the control of the Company.

THIS WARRANTY WILL IMMEDIATELY VOID if any of the following conditions are found:

1. Product is used for purposes other than those for which it was designed and manufactured;
2. Product was not installed in accordance with applicable codes, ordinances and good trade practices;
3. Product was not installed by a Franklin Certified Contractor or Franklin Key Dealer; or
4. Product was damaged as a result of negligence, abuse, accident, misapplication, tampering, alteration, improper installation, operation, maintenance or storage, nor to an excess of recommended maximums as set forth in the product instructions.

NEITHER SELLER NOR THE COMPANY SHALL BE LIABLE FOR ANY INJURY, LOSS OR DAMAGE, DIRECT, INCIDENTAL OR CONSEQUENTIAL (INCLUDING, BUT NOT LIMITED TO, INCIDENTAL OR CONSEQUENTIAL DAMAGES FOR LOST PROFITS, LOST SALES, INJURY TO PERSON OR PROPERTY, OR ANY OTHER INCIDENTAL OR CONSEQUENTIAL LOSS), ARISING OUT OF THE USE OR THE INABILITY TO USE THE PRODUCT, AND THE BUYER AGREES THAT NO OTHER REMEDY SHALL BE AVAILABLE TO IT.

THE WARRANTY AND REMEDY DESCRIBED IN THIS LIMITED WARRANTY IS AN EXCLUSIVE WARRANTY AND REMEDY AND IS IN LIEU OF ANY OTHER WARRANTY OR REMEDY, EXPRESS OR IMPLIED, WHICH OTHER WARRANTIES AND REMEDIES ARE HEREBY EXPRESSLY EXCLUDED, INCLUDING BUT NOT LIMITED TO ANY IMPLIED WARRANTY OF MERCHANTABILITY OR FITNESS FOR A PARTICULAR PURPOSE, TO THE EXTENT EITHER APPLIES TO A PRODUCT SHALL BE LIMITED IN DURATION TO THE PERIODS OF THE EXPRESSED WARRANTIES GIVEN ABOVE.

DISCLAIMER: Any oral statements about the product made by the seller, the Company, the representatives or any other parties, do not constitute warranties, shall not be relied upon by the buyer, and are not part of the contract for sale. Seller's and the Company's only obligation, and buyer's only remedy, shall be the replacement and/or repair by the Company of the product as described above. Before using, the user shall determine the suitability of the product for his intended use, and user assumes all risk and liability whatsoever in connection therewith.

Some states and countries do not allow the exclusion or limitations on how long an implied warranty lasts or the exclusion or limitation of incidental or consequential damages, so the above exclusion or limitations may not apply to you. This warranty gives you specific legal rights, and you may also have other rights which vary from state to state and country to country.

\*Contact Franklin Electric Co., Inc. Export Division for International Warranty.



**Franklin Electric**

9255 Coverdale Road, Fort Wayne, Indiana 46809  
Tel: 260.824.2900 • Fax: 260.824.2909

[www.franklin-electric.com](http://www.franklin-electric.com)